



W.D. Turner Company, Inc.

Sales & Technical Services

#7 Whitaker Place
Thomasville, North Carolina 27360

Phone: (336) 882-4931

Fax: (336) 882-5175

www.WDturner.com

NOTICE

This Manual or Spec Sheet was provided through our web site to assist Customers who purchased equipment through W. D. Turner Company, Inc.

Please do not operate, repair or modify equipment without proper training. Our company provides on-site calibrations, repairs and training. Please contact our office for free quotes or more information.

Please use this Manual or Spec Sheet at your own risk. We welcome inquires about this equipment. Telephone and email technical support is provided free for our customers.

You are invited to visit our web site at:

www.wdturner.com

Thank you for considering our products and services!



MATERIALS TESTING MACHINE

USER MANUAL

LLOYD INSTRUMENTS LTD

Forum House
12 Barnes Wallis Road
Segensworth East
Fareham
Hampshire
PO15 5TT

Tel: +44 (0) 1489 486399
Fax: +44 (0) 1489 885118
Email: techsupport@lloyd-instruments.co.uk
Internet: www.lloyd-instruments.co.uk

June 2001.

User Manual: Part No: 01/3083
Version: 1.0

For use with:-

<u>Machine Type</u>	<u>Pt. No.</u>
LR5K <i>Plus</i> with Console.	01/3051
LR5K <i>Plus</i> no Console	01/3071
LR5K <i>Plus</i> Extended with Console.	01/3073
LR5K <i>Plus</i> Extended no Console.	01/3072
LR5K <i>Plus</i> Pogo with Console.	01/3075
LR5K <i>Plus</i> Pogo no Console	01/3074
LR10K <i>Plus</i> with Console.	01/3052
LR10K <i>Plus</i> no Console	01/3076
LR10K <i>Plus</i> Extended with Console.	01/3078
LR10K <i>Plus</i> Extended no Console.	01/3077
LR10K <i>Plus</i> Pogo with Console.	01/3080
LR10K <i>Plus</i> Pogo no Console	01/3079



International Symbols

Caution! Refer to this manual before using your
LR *Plus* Materials Testing Machine

CAUTION

**HIGH FORCES ARE OFTEN INVOLVED WITH THE
MATERIAL TESTING PROCESSES.**

THE MACHINE IS POWERED BY MAINS SUPPLY VOLTAGE

**TO MAINTAIN ALL ASPECTS OF THE SPECIFICATION,
ONLY LLOYD INSTRUMENTS APPROVED ACCESSORIES
CONNECTIONS AND COMPONENTS SHOULD BE USED**

**STRICTLY ADHERE TO ALL SPECIFIED SAFETY
PROCEDURES**

**READ THIS MANUAL BEFORE USING THE MATERIALS
TESTING MACHINE**

CE DECLARATION OF CONFORMITY

Printed below is a copy of a Lloyd Instruments declaration that the LR *Plus* you have meets the requirements for CE marking. Actual copies of the certificate for your type of LR *Plus* may be obtained from Lloyd Instruments Ltd.

DECLARATION OF CONFORMITY

NAME AND ADDRESS OF MANUFACTURER

Lloyd Instruments Limited,
Forum House,
Barnes Wallis Road,
Segensworth East,
Fareham,
Hampshire,
PO15 5TT
ENGLAND.

DESCRIPTION OF EQUIPMENT

Materials Testing System model LR5K *Plus*

DIRECTIVES COMPLIED WITH

LOW VOLTAGE DIRECTIVE (73/23/EEC) ('LVD')
EMC DIRECTIVE (89/336/EEC) ('EMC')

HARMONISED STANDARDS USED

BS EN 61010 - 1: 1993
BS EN 50081 - 1: 1992
BS EN 50082 - 1: 1992

IDENTIFICATION OF SIGNATORY

KEVIN KIRBY
Product Development Manager

..........DATE 05/06/2001

CONTENTS

1.0	INTRODUCTION.....	1
1.1	INTRODUCTION.....	1
1.2	SAFETY.....	3
2.0	ELECTRICAL SAFETY.....	4
2.1	ELECTRICAL SAFETY.....	4
3.0	INSTALLATION	6
3.1	UNPACKING	6
3.2	SETTING UP YOUR MACHINE	6
3.3	LIFTING WITH A PALLET	7
3.4	LIFTING WITH STRAPS.....	8
3.5	LIFTING WITH A FORKLIFT.....	9
3.6	SETTING UP POGO LR <i>PLUS</i>	9
3.7	FITTING AND MOVING THE CONSOLE (OPTIONAL)	12
3.8	VOLTAGE SELECTION.....	14
3.9	ON-OFF SWITCH.....	14
3.10	FITTING THE LOAD CELL.....	15
3.11	ADDITIONAL LOAD CELL.....	15
4.0	LOAD CELLS.....	16
4.1	CARE OF LOAD CELLS.....	16
5.0	CONTROL PANEL	18
5.1	CONTROL PANEL DESCRIPTION	18
5.2	KEYPAD OPERATION AND DESCRIPTION	18
5.3	THE DISPLAY.....	21
5.4	“SWITCH-ON” DISPLAY	22
6.0	PERFORMING A TEST	24
6.1	PERFORMING A TEST.....	24
6.2	TEST PARAMETERS	24
6.3	SELECTING A TEST.....	26
6.4	STARTING A TEST	29
6.5	STOPPING A TEST.....	30
6.6	PRINTING TEST RESULTS.....	30
6.7	CANCELING OR ACCEPTING THE RESULTS.....	30
6.8	VIEWING THE STATISTICS.....	31
6.9	ERROR CONDITIONS	32

CONTENTS

7.0	SETTING UP A NEW TEST	33
7.1	PRE-DEFINED TEST SETUPS.....	33
7.2	DEFAULT GLOBAL SETTINGS	34
7.3	EDITING A PRE-DEFINED TEST SETUP	34
7.4	PASSWORD ACCESS	34
7.5	RENAMING A TEST.....	35
7.6	DELETING A TEST.....	35
7.7	GLOBAL SETTINGS.....	36
7.8	SETTING A PASSWORD	36
7.9	SAFETY LOAD LIMIT.....	37
7.10	SLOW JOG SPEED.....	37
7.11	SETTING FOR PRINTER.....	37
7.12	GRIP PROTECTION SETTINGS	37
7.13	CURRENT LANGUAGE	38
7.14	TEST SETUP DISPLAY.....	38
7.15	TEST TYPE.....	38
7.16	TEST OPTIONS	41
7.17	TEST RESULTS.....	44
7.18	PASS/FAIL VALUES.....	45
7.19	DEFINING SAMPLE.....	45
7.20	PRE-TEST QUESTIONS.....	46
8.0	OPERATIONAL PRECAUTIONS	47
8.1	SAFETY.....	47
8.2	EMERGENCY STOP	49
8.3	SPLINTER SHIELDS.....	49
8.4	LOWER ANCHOR PIN ADJUSTMENT.....	50
8.5	LIMIT STOPS.....	51
8.6	ERROR CONDITIONS	52
9.0	CLEANING AND MAINTENANCE.....	56
9.1	CLEANING EXTERNAL FINISH AND TRIM.....	56
9.2	MAINTENANCE	56
10.0	SPECIFICATION.....	57
10.1	TECHNICAL SPECIFICATION LR5K <i>PLUS</i>	57
10.2	TECHNICAL SPECIFICATION LR10K <i>PLUS</i>	58
10.3	OVERALL DIMENSIONS LR5K & LR10K <i>PLUS</i>	59
10.4	RS232 LEADS.....	60
10.5	CONSOLE LEAD.....	61

1.0 INTRODUCTION

1.1 INTRODUCTION

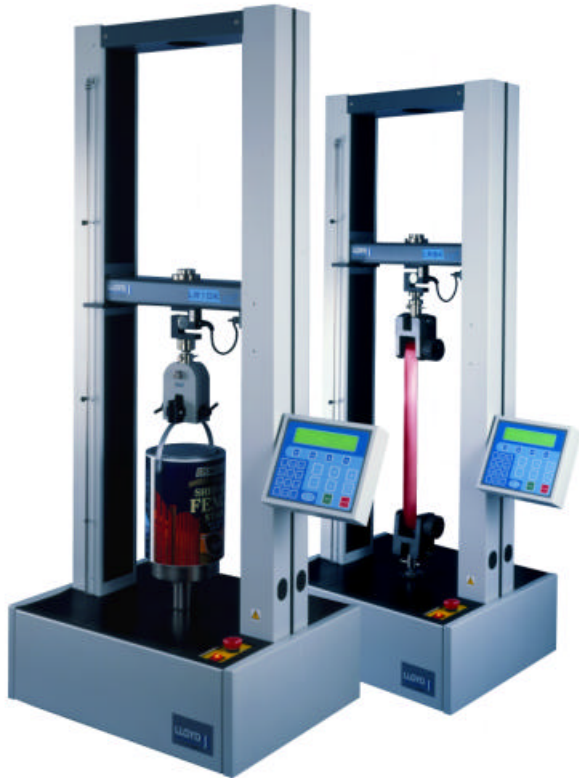

LR5K Plus & LR10K Plus With Console fitted

Welcome to your new Lloyd Instruments LR *Plus* series advanced, twin column, materials testing machine. It incorporates an extensive range of features making it ideal for performing complex testing applications. The machine is microprocessor controlled and uses world proven 32 bit technology for highly accurate load measurement and rapid data acquisition. The optional integral user interface consists of a side mounted control console with large, positive action membrane switches, allowing complex tests to be performed at the touch of a button. A large, back lit Liquid Crystal Display shows the

1.0 INTRODUCTION

test and set-up information in multi-lingual, multi-unit format. The stand alone systems is capable of storing up to 600 test results from a choice of 10 programmable test set-ups, or may be connected via its RS232 output to a personal computer running NEXYGEN™ software, providing almost unlimited testing capability and result manipulation facilities.

The high stiffness frame incorporates a crosshead guidance system to prevent side loading of the sample under test. The crosshead is driven by twin lead screws and a high precision servo motor and DC servo system to achieve a wide range of speeds throughout the full load range. The machine is capable of running full load at full speed. A range of highly accurate, interchangeable loadcells is available for tension, compression and cycling through zero force measurements. The system is ideal for use in production, quality control, educational and research environments.

All LR *Plus* series systems are designed to meet a broad range of applications. This is achieved mainly through the embedded control software and easily configurable data acquisition software, available as an optional extra. NEXYGEN software is fully WINDOWS™ compliant and compatible, it seamlessly integrates with contemporary Microsoft Office programs using OLE2 technology. The program is easy to use, making use of drop down windows prompts, drag and drop, cut and paste routines. Data can easily be exported to programs such as Excel, Access, Outlook and Powerpoint for further manipulation, and enhanced presentation. NEXYGEN software contains a library of pre-programmed test setups for conducting fully automated tests, in accordance with international standards.

1.0 INTRODUCTION

For advice and information about the **NEXYGEN** data analysis and applications software, please contact Lloyd Instruments Sales Department on telephone number:- +44 (0) 1489 486399 or Fax: +44 (0) 1489 885118 or Email: general@lloyd-instruments.co.uk

1.2

SAFETY



Materials testing machines are very safe to use providing the instructions presented in this manual are followed precisely. We would like draw your attention to both the Electrical Safety (Section 2.0 page 4) and Operational Precautions, (Section 8.0 page 47). Please refer to both sections for details on safe operation of this equipment before operating your materials testing machine.

Transparent splinter shields are available as an option to enclose the test sample if there is any danger of samples shattering as a result of the test. These shields have an electronic interlock such that the test cannot be started until the hinged shield is closed. While not mandatory for many applications and countries, Lloyd Instruments strongly recommend that users consider fitting this option.

2.0 ELECTRICAL SAFETY

2.1 ELECTRICAL SAFETY

1. The LR *Plus* materials testing machine has been designed to meet the requirements of BS EN 61010-1 : 1993 Safety requirements for electrical equipment for measurement, control and laboratory use.
2. The User Manual contains some information and warnings, which have to be followed by the user to ensure safe operation and to retain the machine in safe condition.
3. The machine has been designed for indoor use. It may occasionally be subjected to temperatures between +5°C and -10°C without degradation of its safety.
4. Before switching on the machine make sure that it is set to the voltage of the mains electricity supply.
5. This machine complies with electrical safety grade Class 1, which means that it is an “earthed apparatus” and requires the mains plug to contain a protective earth terminal. The mains plug must only be inserted in a socket outlet provided with a protective earth contact. The protective action must not be negated by the use of an extension cord without a protective conductor.
6. The machine must be disconnected from all voltage sources before it is opened for any adjustments, replacement, maintenance or repair.
7. Capacitors inside the machine may still be charged even if the machine has been disconnected from all voltage sources.

2.0 ELECTRICAL SAFETY

8. Any adjustment, maintenance or repair of the opened machine connect to the mains supply voltage should be avoided as far as possible but if inevitable, must only be carried out by a skilled person who is aware of the hazard involved.
9. Make sure that only fuses with the required rated current and of the specified type are used for replacement. The use of makeshift fuses and the short-circuiting of fuse holders is prohibited.

3.0 INSTALLATION

3.1 UNPACKING

All packing material should be carefully removed from the testing machine and a careful visual inspection should be made to ensure that there is no obvious transit damage. The following items should be in this package:

This User Manual
Straining Frame
Control module (Console) (if ordered)
Console cable. (09/0710)
Power input cable
NEXYGEN Software (if ordered)
RS232 cable (09/0639)
Printer RS232 cable, optional (09/0721)
Load cell(s) (as per order)
Various grips and adaptors (as per order)
2 x Grip/adaptor pins , 1 x Anchor pin
1 x "C" Spanner, 1 x 5mm Allen Key

If there is any damage, or parts missing, please report this to your dealer or Lloyd Instruments without delay.

3.2 SETTING UP YOUR MACHINE

The LR *Plus* Materials Testing Machine is a heavy item and great care should be taken in choosing the location where it is to be installed. If it is to be bench mounted you must ensure the bench is capable of remaining firm and stable, withstanding the combined weight of the machine and any accessories supplied. Please see the Specification page at the end of this manual for the weight of the apparatus. The machine must be vertical, whether bench or floor mounted; otherwise the results may be affected, particularly for very low loads.



It must be positioned such that the front of the machine can be easily accessed and that THE EMERGENCY STOP BUTTON IS NOT OBSTRUCTED IN ANY WAY.

3.0 INSTALLATION

Please ensure utmost care is taken when lifting, as the machine is heavy. Lifting equipment should be used as necessary. **DO NOT** use the console as a handle when lifting. The recommended methods are described below.



CAUTION

At no time should this machine be lifted by placing hands under the frame

3.3

LIFTING WITH A PALLET

A pallet may be fitted under the machine so that it may be lifted to the desired position with a forklift or suitable lifting trolley.

3.0 INSTALLATION

3.4 LIFTING WITH STRAPS

Lifting straps may be situated under the moving crosshead. Ensure the crosshead is padded to avoid damaging the machine. Care should be taken to ensure that the straps do not interfere with the load cell connection socket.

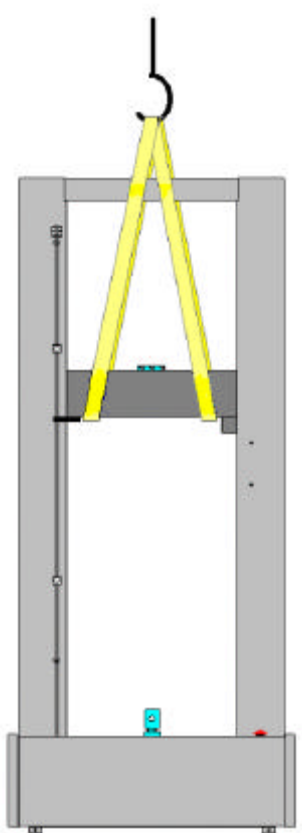

Lifting with Straps

3.0 INSTALLATION

3.5 LIFTING WITH A FORKLIFT

An alternative method is the use of a fork lift truck with the forks under the moving crosshead as shown below. Once again ensure the crosshead is well padded to avoid damage to the machine. Ensure the forks do not damage the load cell socket.

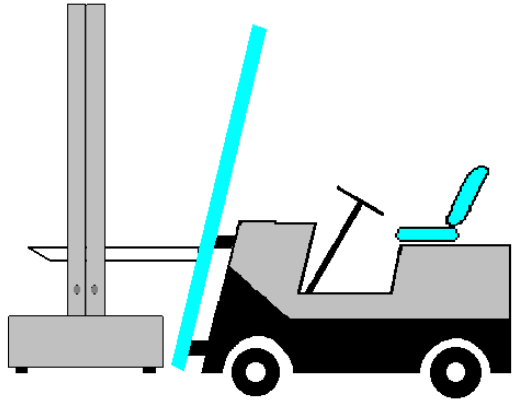

Lifting with a Fork Lift

3.6 SETTING UP POGO LR *PLUS*

Lloyd Instruments Ltd., produces a range of machines that can be mounted on specially designed frames that can be used for testing a wide range of bulky items such as cardboard cartons, crates and furniture.

These “Pogo” machines have a linear bearing fitted in the fixed lower crosshead through which a rod runs, connecting the load cell and the compression platens mounted below the machine within the frame.

3.0 INSTALLATION



LR Plus Pogo mounted on a Carton Crusher Frame.

No specific information about setting up a LR *Plus* Pogo can be issued with the machine on it's own because the size and specification of the mounting frame are decided by the customers specific needs.

The mounting frame should be positioned first and the instructions for set-up and wiring supplied with the mounting frame followed closely.

The LR *Plus* Pogo will have been supplied to you without the frame mounting plates fitted. The fitting of these plates needs to be carried out prior to the machine being lifted onto the Crusher Frame.

The fitting of these mounting plates should only be carried out by a Lloyd Instruments appointed commissioning engineer.

3.0 INSTALLATION

Full fitting and wiring instructions are supplied with the Crusher Frame. Fitting and wiring of the Emergency Stop Buttons and Console are designed to meet each customer's specific needs.

Because the mounting plates protrude from the bottom of the LR *Plus*, no attempt should be made to stand the machine on it's own. It will only be stable when it is fitted and secured to the mounting frame.

Suitable lifting equipment should be employed.

The Pogo Rod should be fitted last once the LR *Plus* is secured to the top of the frame. Insert the rod through the bearing on the lower (fixed) crosshead of the LR *Plus* and connect to the Bottom Platen. Connect to the Loadcell last.

3.0 INSTALLATION

3.7 FITTING AND MOVING THE CONSOLE (OPTIONAL)

The console is fitted to the right side of the machine. The height and the angle of the console may be set to give the best position for viewing and operation.

The height of the console is adjustable over a range of approximately 240mm on a standard machine when using the external connection cable supplied with the machine. If it is required to position the console nearer to the top of the machine or on the side of a compression cage, a longer cable may be obtained from Lloyd Instruments.

To maintain EMC compatibility only leads supplied by Lloyd Instruments should be used.

To connect the console to the machine:-

1. Remove the outer two cap head screws from the adjustable backing plate located near the bottom of the right hand column, using the 5mm Allen Key supplied
2. Adjust the backing plate to the required height by loosening the centre cap head screw. Tighten the screw when the backing plate is in the desired position
3. Fit the console assembly to the backing plate with the two cap head screws removed earlier. The angle of the console may be set prior to tightening the screws.
4. Plug the 37 way cable into the 37 way socket on the rear of the console and the other end into the socket marked SKT 2 CONSOLE on the back of the machine. Tighten the locking screws to retain both ends of the cable.

3.0 INSTALLATION

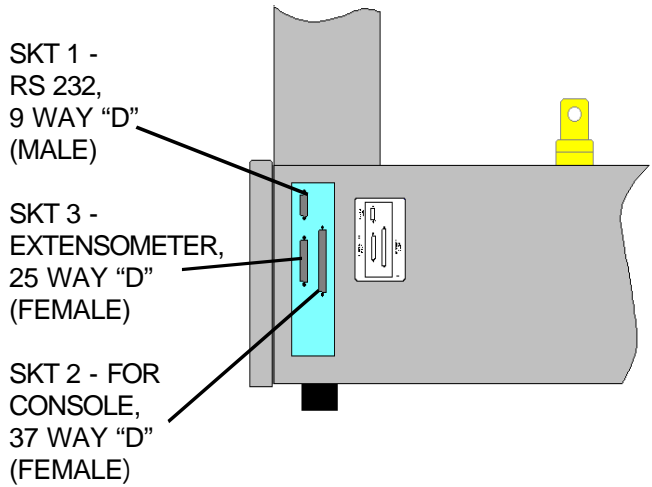

Section of Rear View LR *Plus* Machine

3.0 INSTALLATION

3.8 VOLTAGE SELECTION

The LR *Plus* can be used with electricity supplies of either 230Vac $\pm 10\%$ or 115Vac $\pm 10\%$. The power input cable should be inserted at the rear of the machine. Before switching on the machine you **MUST** check the correct voltage has been selected on the mains input connector. Ensure that the selection is correct for the voltage range of your power supply. To change the voltage rating, use a screwdriver to open the voltage selector. The screwdriver should then be used to move the selector from the 115V position to the 230V position as appropriate. You **MUST** also check that the fuse rating is suitable for the supply voltage that you are using. The fuses (live and neutral) are located inside the power input connector. The fuse ratings for 230V and 115V are given in Section 10: Technical Specifications. (Page 57)

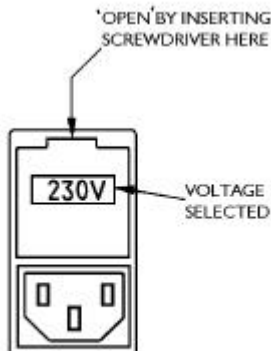

Voltage Selection

3.9 ON-OFF SWITCH

The power on switch is located on the machine base at the front right of the main base unit. The switch is a rocker type with positions 0 and 1. By selecting 1 power will be supplied to the machine.

3.0 INSTALLATION

3.10 FITTING THE LOAD CELL

Before the machine is powered up, or any test set-ups are entered, the Load Cell should be fitted.

Carefully unpack the Load Cell(s) supplied with your machine. Please make **all operators** aware that they are precision load measuring devices and should be treated with great care. **Please read SECTION 4.0 LOAD CELLS (next page) before proceeding further.**

3.11 ADDITIONAL LOAD CELL

The following standard Load Cells are available for your LR *Plus*.

	Description	Part Number
XLC-0005-A1	0.5% accuracy 5N	01/2946
XLC-0010-A1	0.5% accuracy 10N	01/2360
XLC-0020-A1	0.5% accuracy 20N	01/2950
XLC-0050-A1	0.5% accuracy 50N	01/2361
XLC-0100-A1	0.5% accuracy 100N	01/2480
XLC-0250-A1	0.5% accuracy 250N	01/2419
XLC-0500-A1	0.5% accuracy 500N	01/2362
XLC-1000-A1	0.5% accuracy 1000N	01/2419
XLC-2500-A1	0.5% accuracy 2500N	01/2363
XLC-5000-A1	0.5% accuracy 5000N	01/2364
XLC-10K-A1	0.5% accuracy 10kN	01/2365

4.0 LOAD CELLS

4.1 CARE OF LOAD CELLS

ALL machine operators should be aware that Lloyd Instruments' load cells are precision force-measuring instruments, which should be treated with the utmost care to avoid accidental damage. Low force cells are easily damaged if abused or used without sufficient care:

1. Do not submit load cells to physical shock of any kind. **DO NOT DROP!**
2. When a load cell is removed from a machine immediately put it in a safe and dry place.
3. To install a load cell: Select the correct size load cell adaptor. Place the adaptor through the hole in the moving crosshead with the thread down. Carefully offer up the load cell and screw the load cell adaptor into the load cell, taking care to ensure that the locating dowel on the load cell sits in one of the holes on the under side of the moving crosshead and the connecting cable is on the same side as the connecting socket. Tighten the load cell adaptor in the load cell thread with the C spanner provided. Insert the load cell plug in the socket on the under side of the moving crosshead and finger tighten the two retaining screws. Fit the eye end to the load cell and tighten with the C spanner supplied.
4. When installing the upper grip (particularly heavy ones) on the load cell eye end, avoid bumping the eye end. If the grip is a close fit, **DO NOT FORCE IT**, establish the reason and rectify. Immediately set, or re-set, the bottom limit stop so the grips will not meet when the crosshead is lowered. See section **8.5 LIMIT STOPS**.
5. In both tension and compression tests, centre the specimen in line with the axis of the load cell and the bottom fixed anchor pin to avoid side thrust.

4.0 LOAD CELLS

6. In compression tests, care must be taken to avoid bringing the platens together or against solid specimens at high speed. Cells thus damaged cannot be repaired. Ensure that the lower crosshead limit is set correctly. See section **8.5 LIMIT STOPS**.
7. In compression tests, if special lower fixtures are used, ensure that they are fixed in position so they cannot be accidentally moved to block the normal downward movement of the upper fixture, e.g. where a tongue on the upper fixture must fit into a slot in the lower fixture. See section **8.4 LOWER ANCHOR PIN ADJUSTMENT**.
8. Avoid overloading beyond the cell's rated capacity. Prior to testing ensure, if possible, that the maximum force anticipated will not exceed the capacity of the cell installed. If maximum capacity is approached during a test, run the machine at slow speed in local mode, and reverse the crosshead if capacity is exceeded.

Note:

All Lloyd Instruments machines incorporate overload protection, which will stop the machine if capacity is exceeded in either tension or compression. However, at higher speeds, momentum may carry the crosshead far enough after shut-off to damage the cell. In low force cells this distance is very short. Cells thus damaged cannot be repaired.

9. Lloyd Instruments load cells are built to exceed the standards as set out by ASTM, BS, DIN etc. All cells on LR *Plus* machines are user-changeable. Various capacities are available from 5N up to the capacity of the frame. While cells may be used below 10% of capacity it is recommended that, when such lower forces are anticipated, a lower force cell be installed such that the test force will fall in the upper 90% of its range. This will give the best signal to noise performance of the load measuring system.

5.0 CONTROL PANEL

5.1 CONTROL PANEL DESCRIPTION

The unit has a Liquid Crystal Display (LCD) to show set-up information, load and extension values etc. and a key pad to input information for operating the machine when under control of the console. The machine is set up by answering simple questions and entering information when requested. The operating status of the machine is shown and described on the display.

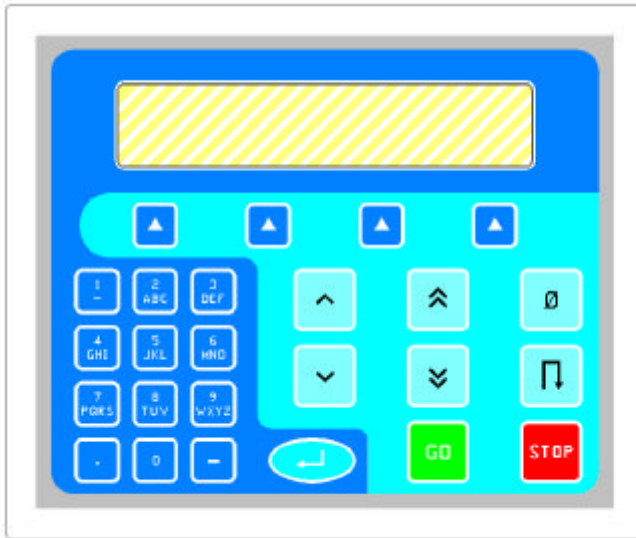

The control Panel

5.2 KEYPAD OPERATION AND DESCRIPTION

The keypad has 25 keys arranged into 4 groups.

5.0 CONTROL PANEL

The **first group** contains 8 keys in the bottom right hand corner of the keypad



The First Group of Keys

GO The GO button is used to start a test from the machine console and is operable from the “Pre-Test” display .

STOP The STOP key is used to stop a test that is being performed from the machine console, i.e. if the machine does not stop automatically or the user requires to abort the test. The STOP key is not operable when the machine is performing a test under the control of an external computer.



This is not an Emergency Stop Button. The Emergency Stop Button (Mushroom) is located on the machine frame base unit and can be used to stop the machine in an emergency situation.

JOG These two keys allow the crosshead to be moved slowly into position when loading and removing samples. They are available when a test is not being performed and only operate whilst pressed. The crosshead will run at a user pre-set jog speed (a *set-up* option).

Up ^

Down v

5.0 CONTROL PANEL

FAST
Up 
Down 

These two keys allow the crosshead to be moved at maximum speed and therefore it is essential to ensure there are no obstructions. These keys should only be used for moving large distances and not for final adjustment when the grips are close together. They are available when a test is not being performed and only operate whilst pressed.

ZERO 

Pressing this key sets the load and extension values to zero. This is normally carried out at the start of a test but can be used at any time when not performing a test. If Auto Zero was selected in the set-up routine the system will automatically zero when GO is pressed.

RETURN 

Pressing this key returns the crosshead to the position where the zero button was last pressed. The crosshead will move at maximum speed. The return button is available when a test is not being performed.

The second group contains 4 keys directly below the display. These "Soft Keys" are used to select various options that are identified by the text displayed on the lower lines of the display as described later.



The Second Group of Keys

5.0 CONTROL PANEL

The **third group** contains 12 keys on the left hand side of the keypad. These keys are used to enter text or numbers and are labelled 1 to 9, 0, decimal point and negative sign. Most keys also double up as alphabetical entry keys similar to the style used on mobile phones.

The Third Group of Keys



The **fourth “group”** is one key in the bottom centre of the keypad. This key is the **ENTER** key which is used to accept any entered text, value or unit. It is also used to accept the entries on a completed display and to show the PREVIOUS display. The **ENTER** key is not available when a test is being performed or when input from another key is required.

The Fourth “Group” of Keys



5.3

THE DISPLAY

The display, which has 4 lines of 40 characters, is used to show or request information. The information displayed depends upon the status of the machine but generally, the top line displays a title or help information for each display. The lower lines are split into 4 blocks, one block above each Soft Key, to indicate the function of that key.

5.0 CONTROL PANEL

5.4 “SWITCH-ON” DISPLAY

When first switched on the display will be blank while the system performs some routine checks.

After a couple of seconds the display will show information about the machine and the version of the embedded software installed.

```
LLOYD INSTRUMENTS LTD
LR PI us Material s Testing Machine
Version 3.0 Issue 44
Load Cell 001234 5kN
```

This information is displayed for three seconds after which the test selection screen is displayed.

The next display shows that a test called CYCLE_TEST has been defined. The number in brackets shows the number of sample results currently stored with this test.

```
Select the required test
CYCLE_TEST (150 Samples)

Test      <      >      Edit
```

A total of 600 sample results can be stored across all test set-ups. If the total number of samples currently stored with all the test set-ups exceeds 500 then the third line will display a warning message.

```
Select the required test
CYCLE_TEST (501 samples)
Warning: Only space for 99 more samples
Test      <      >      Edit
```

As the left and right arrow (< >) Soft Keys are pressed, the names of the previously defined tests will be shown.

5.0 CONTROL PANEL

When the first test is displayed, the left arrow will be hidden as shown below.

Select the required test LIMIT_TEST (150 samples)		
Test	>	Edit

When the last test is displayed, and less than 10 set-ups have been defined the display below will be shown.

Select the required test New Test	
<	Create

To define a test, refer to Section **7.0 SETTING UP A NEW TEST**, noting that the supervisor may add a password to prevent the operator from entering the EDIT or CREATE modes.

6.0 PERFORMING A TEST

6.1 PERFORMING A TEST

The LR *Plus* machines can be used to perform tests in 2 modes. Firstly as a “stand alone” machine or under the control of a computer running NEXYGEN software.

If the machine is to be used with a computer and NEXYGEN software, then the NEXYGEN Software User Manual should be read in conjunction with this manual. The machine should be connected to the computer with the RS232 lead supplied. When the machine is on and ready, the computer connected with the lead supplied and NEXYGEN running, connection between the machine and computer is automatic.

If the LR *Plus* machine is being used in “stand alone” mode, proceed as follows. The following information will also be needed for “setting up” the machine with grips, samples etc.

6.2 TEST PARAMETERS

SAMPLE PREPARATION The Jog Keys are used to prepare for a test. The accessories being used will be dependent on the type of test being conducted.

LOAD CELLS The correct load cell should be fitted in the machine for the application being undertaken. Great care should be taken with these as they are precision measurement devices and can be damaged if used incorrectly. Please read Section 8.0 carefully before proceeding further.

6.0 PERFORMING A TEST

GRIPS/ ADAPTORS

It is important that grips are fitted along the central straining axis of the machine and that no side loads are applied to the load cells as this will affect the accuracy of the load readings. The grips should be connected to the load cell and the bottom anchor pin using only the pins provided. Care should be taken not to exceed the load rating of the grips. It is important to ensure that the grips used are suitable for the material under test. Any slippage of the material in the grips will affect both load and extension readings.

EXTEN- SOMETERS

It is important to understand that the extension that the crosshead moves does not give a true reading of the strain in the samples. If we consider a dumbbell sample for instance, the strain will be different at different positions along the sample and no account is being taken of the take up of slack or bedding in of the grips. For accurate strain readings we would strongly recommend the use of a Lloyd Instruments extensometer, which is suited for the material under test.

ENVIRON- MENTAL CHAMBERS

If an environmental chamber is used with your materials testing machine there should be sufficient room behind the machine to slide the oven back away from the working area. It is important to ensure that the cut-off valve for the liquid coolant should be in an accessible place. Grips and other accessories are fitted to the machine with the environmental chamber in its fully forward position. The access holes at the top and bottom of the chamber should be positioned as centrally as possible along the straining access of the machine.



Extreme care should be taken when dismantling grips or extracting samples after a test in the Environmental Chamber. This should be done only with suitable protective clothing, i.e. gloves, to prevent risk of burns.

6.0 PERFORMING A TEST

6.3 SELECTING A TEST

The user selects the required existing pre-programmed test by pressing the left and right arrow Soft Keys until the required test is shown on the display, then pressing the **Test** Soft Key.

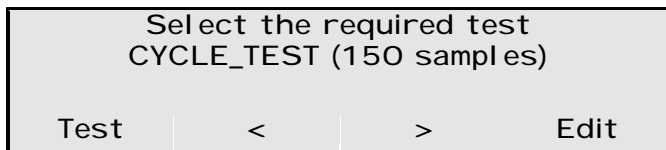

Depending on how the test has been set up one or more of the following screens will be displayed. Refer to Section **7.0 SETTING UP A NEW TEST** for details on setting these options.

If an external extensometer has been selected for use then the following screen will be displaying if the required extensometer is not fitted.

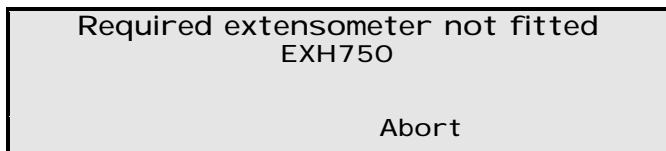

If the external extensometer is fitted but has a selectable range the following screen will be displayed.

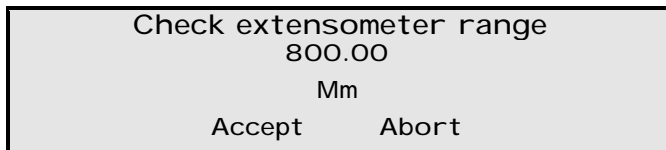

The external extensometer range must be set to the range displayed on this screen for the measurement of extension to be correct.

6.0 PERFORMING A TEST

If a plotter output has been selected, then the following screen will be displayed.

Check Plotter Calibration			
Maximum Load	100.0N		
Maximum Extension	100.0mm		
Accept	Abort	Calibrate	

Pressing the Calibrate Soft Key allows the user to the following screen

Output a Plotter Limit			
		Output	Output
		100.0	100.0
Accept	Abort	N	mm

If the batch questions option is turned on, then the following screen will be displayed.

Press a key to change a parameter			
OPERATOR	BATCH		
NAME	NUMBER		
			Suspend

The information can only be entered when a new batch is started i.e. when sample number 1 is to be tested. The operator can answer the questions by pressing the Soft Key below each question.

Pressing the **Enter** key will confirm all the answers to the batch questions and show the pre-test display.

If the operator is continuing with a previously suspended batch, then the batch questions, and their answers, will be displayed in a "view only" mode.

OPERATOR	DAVE		
BATCH NUMBER	B21_G		
		Continu	Suspend

6.0 PERFORMING A TEST

Here the operator will be given the option to **Continue** with the previously suspended batch or to **Suspend** the batch again by pressing the appropriate Soft Keys.

Press GO to test Sample 1			
6.00mm × 3.00mm		MOULD_32	
Ext -	10.00mm	Load -	276N
Sample	Stats	Reset	Suspend

On the top line of the Pre-test display help information is shown. On the second line, the right hand side shows the test setup name.

On the third line, Extension and Load are displayed. Extension - or $\bar{\quad}$ indicates the direction of the extension from the “soft zero” position. “Soft zero” being the position at which the **AE** key was last pressed.

Load - or $\bar{\quad}$ indicates a Tensile Force or Compressive Force, respectively.

If the sample questions option is turned on, then next to the test name the sample width and thickness, diameter or area information will be shown. The **Sample** Soft Key will also be displayed. Refer to Section **7.0 SETTING UP A NEW TEST** for details on setting these options.

Pressing the **Suspend** Soft Key returns to the test selection display but saves the statistics and last sample number ready to continue the batch later.

Pressing the **Reset** Soft Key resets the all the batch results, sets sample number to 1 and shows the display that would be selected when first selecting the test, i.e. batch or pre-test. This is only done after conformation by the operator.

Pressing the **Stats** Soft Key will show the statistics for the samples tested so far and allow them to be printed.

6.0 PERFORMING A TEST

Pressing the **Sample** Soft Key will display the sample question screen shown below.

Press a key to change a parameter			
Gauge	Width	Thickness	SAMPLE
25.00	6.00	3.00	NUMBER
mm	mm	Mm	

This display allows the operator to enter the sample dimensions and a single description. The text for the 3 sample fields depends upon the test mode and sample type. The first field will say **Gauge** for Tension or **Height** for Compression. The second field will say **Width** for Rectangular, **Diameter** for Circular or **Area** for Area. The third field will only be displayed for Rectangular samples and will say **Thickness**. The fourth field will display the sample question define in the test setup. The Soft Keys allow the sample dimensions to be altered and the sample question to be answered.

6.4 STARTING A TEST

When all the test parameters have been set as per **5.3 SELECTING A TEST** above, press **GO** to start the test and display one of the screens below.

For a Limit Test:

Performing Test		MOULDED_RUBBER	
Moving to Limit point			
Ext -	10.00mm	Load -	276N

or for a Cycling Test

Performing Test		MOULDED_RUBBER	
Moving to Limit point. Cycle 3			
Ext -	10.00mm	Load -	278N

6.0 PERFORMING A TEST

6.5 STOPPING A TEST

When the test ends, either automatically or if the user presses the **STOP** key, the post test screen will be displayed

Sample 1 Passed			
Pk Load	367N	Brk Load	237N
Pk Ext	126.50mm	Brk Ext	157.80mm
Print	Stats	Accept	Cancel

This screen will display different amounts of information depending on how the test has been set up. Refer to Section **7.0 SETTING UP A NEW TEST** for details on setting these options.

6.6 PRINTING TEST RESULTS

Pressing the **Print** Soft Key will either print just the single result or, if **All** was selected for the **Sample Printout** option in the test setup, together with the machine setup details, i.e. test speed etc.

6.7 CANCELLING OR ACCEPTING THE RESULTS

Pressing the **Cancel** Soft Key will cancel the result (abort) and remove the result from the batch.

Pressing the **Accept** Soft Key or the **ENTER** key will accept the results and add them to the batch.

6.0 PERFORMING A TEST

6.8 VIEWING THE STATISTICS

Pressing the **Stats** Soft Key will accept the result and show the statistics screen as below:-

	Pk Load	Pk Ext	
Mean	367N	126.57m	
Dev'n	5N	24.18mm	
Print			>

Pressing **>** Soft Key will show the second statistics screen:-

	Brk Load	Brk Ext	
Mean	137N	155.03m	
Dev'n	12N	54.13mm	
Print			<

Pressing the **Print** Soft Key from the statistics screen will show the 'print options' screen shown below:-

Print options for CYCLE_TEST		
Stats Only	Brief Report	Full Report

Pressing the **Stats Only** Soft Key will give a table of statistics only, without the test value.

Pressing the **Brief Report** Soft Key will give a table of test values and statistics.

Pressing the **Full Report** Soft Key will give a table of test values, statistics and test setup information.

6.0 PERFORMING A TEST

6.9 ERROR CONDITIONS

If an error condition exists the cause of the error will be shown on the display. This error must be cleared before you can proceed with the test. See **Section 8.6** for details of error messages

7.0 SETTING UP A NEW TEST

7.1 PRE-DEFINED TEST SETUPS

The LR *Plus* is supplied with three pre-defined test setups and one for new test setups, these are:-

LIMIT_TEST, CYCLE_TEST, BREAK_TEST, NEW_TEST

These Default test setups are as follows:-

Test name >	LIMIT_TEST	CYCLE_TEST	BREAK_TEST	NEW_TEST
Test Type	Settings			
Test mode	Tension	Tension	Tension	Tension
Test type	Limit	Cycling	Limit	Limit
Limit position	10.0mm	10.0mm	5kN	10.0mm
Home position		0.0mm		
No. of cycles		10		
Preload	0.0N	0.0N	0.0N	0.0N
Speed	250mm/min	250mm/min	25mm/min	250mm/min
Hold	0 seconds			0 seconds
Test Options				
Sharp Break detector	off	off	on	off
% Break Detector	off	off	off	off
Return to zero	manual	Manual	manual	manual
Zero readings	manual	Manual	manual	manual
Sample printout	All	All	All	All
Extensometer Used	Internal	Internal	Internal	Internal
Test Results				
Peak Load	N	N	N	N
Extens'n at peak load	mm	mm	mm	mm
Break load	N	N	N	N
Extension at Br'k load	mm	mm	mm	mm
Pass/fail Checks	off	off	off	off
Define Sample				
Sample type	Rectangular	Rectangular	Rectangular	Rectangular
Gauge	25.00mm	25.00mm	25.00mm	25.00mm
Width	6.00mm	6.00mm	6.00mm	6.00mm
Thickness	3.00mm	3.00mm	3.00mm	3.00mm
1st Batch ? line 1	OPERATOR	OPERATOR	OPERATOR	OPERATOR
1st Batch ? line 2	NAME	NAME	NAME	NAME
2nd Batch ? line 1	BATCH	BATCH	BATCH	BATCH
2nd Batch ? line 2	NUMBER	NUMBER	NUMBER	NUMBER
3rd Batch ? line 1				
3rd Batch ? line 2				
Sample ? line 1	SAMPLE	SAMPLE	SAMPLE	SAMPLE
Sample ? line 2	ID	ID	ID	ID
Batch questions	off	off	off	off
Sample questions	off	off	off	off

7.0 SETTING UP A NEW TEST

7.2 DEFAULT GLOBAL SETTINGS

The Default Global Settings are:-

Field	Setting
Password	<None>
Safety load	50N
Slow jog speed	10mm/min
Data format	Printer
Grip protection Tension	110% of frame rating
Grip protection Compression	110% of frame rating
Language	English

To enter a New Test Setup or Edit a pre-defined setup, proceed as follows.

7.3 EDITING A PRE-DEFINED TEST SETUP

To edit a previously defined test setup, select the required test, using the left and right arrow keys, until the required test is displayed then press the **Edit** Soft Key.

This is the Select/Edit Display.

Select the required test CYCLE_TEST (150 samples)			
Test	<	>	Edit

7.4 PASSWORD ACCESS

If the machine has been given a password, the password entry display will be shown.

Enter the password to edit this test	
BkSp	Clear All

Type the password then press the **ENTER** key .

7.0 SETTING UP A NEW TEST

If the password is not correct, the test Select/Edit Display will be redisplayed.

If the password is correct, the main setup display is shown.

This is the Main Setup Display

Press a key to select an option CYCLE_TEST			
Rename	Global	Delete	Setup

Pressing the **ENTER** key will return to the Select/Edit display.

7.5 RENAMING A TEST

Pressing the **Rename** Soft Key will allow the setup name to be changed. If a new test is created, the name will be automatically set to new_test.

7.6 DELETING A TEST

Pressing the **Delete** Soft Key will allow the selected test setup and all associated sample results to be deleted. The following screen will appear.

Delete Test CYCLE_TEST Are you Sure?	
Yes	no

7.0 SETTING UP A NEW TEST

7.7 GLOBAL SETTINGS

Pressing the **Global** Soft key will allow the Password and Jog speed etc. to be changed. (see **Main Setup Display** page 35.)

Press a key to change a parameter			
Change	Safety	Slow Jog	
Password	50.0	100	
CHRIS	N	mm/min	>

Press a key to change a parameter			
data	set	Current	
format	grip	Language	
printer	protect'n	English	<

7.8 SETTING A PASSWORD

Pressing the Change Password Soft Key brings up the following display:

Change or create the password		
CHRIS		
BkSp		Clear All

Pressing **BkSp** Soft Key deletes one character at a time starting from the right hand end of the password.

Pressing the **Clear All** Soft Key deletes all the characters.

The Alphanumeric keys add new characters to the password the **ENTER** key accepts the password as displayed.

If the password displayed is blank then there will be no password protection.

7.0 SETTING UP A NEW TEST

The password limits access to the edit test setup menus. If a password has been set this password will be required before any parameter of any test setup can be edited. The selection and running of previously defined test setups is not affected.

7.9 SAFETY LOAD LIMIT

The **Safety** limit is intended as an extra protection against accidental injury. It applies when the **JOG** keys are pressed or during return when the crosshead is moving down. Entering a high value for this option will reduce the level of safety provided and should only be done to overcome nuisance errors caused by high friction in some accessories.

7.10 SLOW JOG SPEED

The **Slow Jog** setting allows the user to specify the speed that the crosshead will move when the slow **JOG** keys are pressed.

7.11 SETTING FOR PRINTER

The **Data Format** Soft Key toggles between **Printer** and **ASCII** (ASCII for when a DATALOGGER is to be used).

7.12 GRIP PROTECTION SETTINGS

The **Grip Protection** setting is an additional load limit, which can be used to protect grips or accessories that are being used. The test will be stopped if the value of load exceeds the **Grip Protection** setting during a test.

7.0 SETTING UP A NEW TEST

7.13 CURRENT LANGUAGE

Pressing the **Current Language** soft key allows the user to select the language to be used from the list of languages supported by the machine. The chosen language will be used for all information presented to the user, including information output to a printer.

7.14 TEST SETUP DISPLAY

Pressing the **Setup** Soft Key from the Main Setup Display will show the test setup display.

This is the Test Setup Display

Press a key to Select an Option			
MOULDED_RUBBER			
Test	Test	Test	Define
Type	Options	Results	Sample

7.15 TEST TYPE

Pressing the **Test Type** Soft Key will allow the test type to be defined.

Press a key to change a parameter			
Test	Test	Set	
Mode	Type	Limit	
Tension	Limit	Values	>

Pressing the **>** Soft Key will toggle between the display above and the next display.

Press a key to change a parameter			
Speed	Set		
150	Preload		
mm/min	Values		<

The **test mode** Soft Key toggles between **Tension** and **Compression**.

7.0 SETTING UP A NEW TEST

The **Test Type** Soft Key toggles between **Limit** and **Cycling**. In cycling mode the **Set Limit Values** Soft Key changes to **Set Cycling values**.

Pressing the **Set Limit Values** Soft Key will allow the values to be set.

Press a key to change a parameter	
Limit	Hold
10.00	0
mm	seconds

The limit type, value and unit may be set or changed by pressing the **Limit** Soft Key. The required parameters may then be entered.

If either a **Hold** value is set or if the units of **Speed** are in load rate units sample stiffness information will be displayed.

Press a key to change a parameter			
Limit	Hold	Sample	Initial
10.0	30	Stiffness	100000.0
mm	seconds	Auto	N/mm

Sample Stiffness can be set to **Auto** (see above) or **Manual** (see screen below).

Manual Sample stiffness uses the value entered throughout the test. **Auto sample stiffness** starts from an **Initial** value and throughout the test re-calculates this value.

Press a key to change a parameter			
Limit	Hold	Sample	Stiffness
10.0	30	Stiffness	100000.0
mm	seconds	Manual	N/mm

7.0 SETTING UP A NEW TEST

Pressing the **Set Cycling Values** Soft Key will allow the values to be set.

Press a key to change a parameter		
Limit	Home	Number
20.0	10.0	of Cycles
mm	mm	2

The **Home** position is the start of the Cycle Test position and wherever the machine is resting after loading it will drive first to the **Home** position. After reaching the home position it will drive to the **Limit** position and back to the **Home** position to complete the first cycle. The machine's response to inputs as shown above is illustrated in the NEXYGEN graph shown below

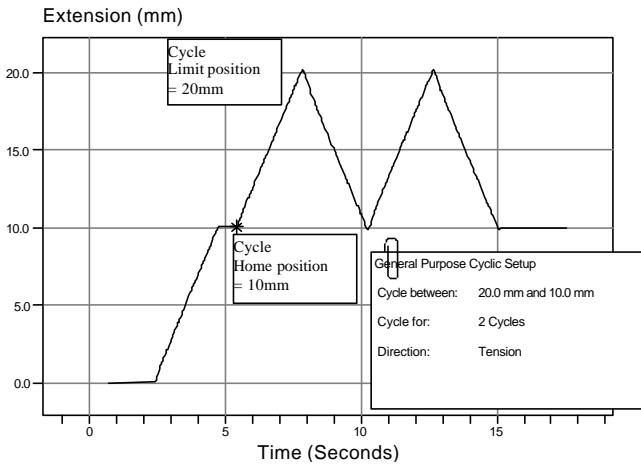

Pressing the **Set Preload** Soft Key will allow the values to be set. It is recommended that the minimum value entered is no less than 1% of the Loadcell value fitted.

7.0 SETTING UP A NEW TEST

Press a key to change a parameter	
Speed	Limit
10	0.00
Mm/min	N

7.16 TEST OPTIONS

Pressing the **Test Options** Soft Key from the test setup display will allow the test options to be set.

Press a key to change a parameter			
Break			
Detector	Return	Zero	
Sharp	Auto	Manual	>

Pressing the > key will toggle between the above display and the next display.

Press a key to change a parameter			
Sample	Extensio'r		
Printout	Used		
All	LR Plus		>

If the > key is pressed the following screen will appear.

Press a key to change a parameter	
Plotter	
Output	
disabled	<

By pressing the **Break Detector** Soft Key the following display is shown

Sharp Break Detector

Press a key to change a parameter		
Sharp	Percent	Start
Break	Break	50
On	Off	N

7.0 SETTING UP A NEW TEST

There are two break detectors, a sharp break detector and a percentage of peak load break detector. Either break detector is turned On or Off by pressing the appropriate Soft Key. Only one break detector can be turned On at a time. When a break detector is turned On, other options are displayed. Both break detectors have a **Start** option and the Percentage break detector also has a **Percentage Break** option.

Percentage of Peak Load Break detector

Press a key to change a parameter			
Sharp	Percent	Start	Break
Break	Break	50	Point
Off	On	N	50 %

The **Start** option sets the threshold above which the peak load must rise before the break detector will start operation. The **Percent Break** option sets the percentage of peak load below which the measured load must fall to constitute a break.

The **Return** and **Zero** options toggle between **Manual** and **Auto**

Pressing the **Extensometer Used** Soft Key will allow the selection of any extensometer currently fitted from the following screen.

Select an extensometer	
LR Plus Materials Testing Machine	
<	>

The left and right arrow (< >) Soft Keys will scroll through the list of currently connected extensometers, (theoretically a maximum of 4 with the internal crosshead position always being listed as one of these). The internal crosshead position extensometer is displayed as the LR Plus materials testing machine,

7.0 SETTING UP A NEW TEST

i.e., LR Plus Press the **ENTER** key to select the displayed extensometer.

If the selected extensometer has a selectable range, then an additional option will be displayed in the Test Options screen.

Press a key to change a parameter			
Sample	Extensometer	Range	
Printout	Used	800.00	
All	EXH750	mm	<

The extensometer range will default to the maximum range of the extensometer but can be changed by pressing the **Range** Soft Key.

7.0 SETTING UP A NEW TEST

Pressing the **Sample Printout** Soft Key, toggles between "Result" and "All". "Result" will print the 4 results and "All" will print the 4 results and the machine parameters.

Pressing the **Plotter Output** Soft Key, toggles between "Disabled" and "Enabled". In the "Enabled" position, the following screen will be displayed where the plotting parameters can be set.

Press a key to change a parameter			
Plotter	load	Ext	
Output	100.0	100	
Enabled	N	mm	<

7.17

TEST RESULTS

Pressing the **Test Results** Soft Key from the Test Setup Display will allow the test results units and pass/fail limits to be set.

Press a key to change a parameter	
Test	Pass/Fai
Result	Checks
Units	Off

Pressing the **Tests Result Units** Soft Key allows the units to be set.

Press a key to change a parameter			
Peak	Peak	Break	Break
Load	Ext	Load	Ext
N	mm	N	mm

7.0 SETTING UP A NEW TEST

7.18 PASS/FAIL VALUES

If **Pass/Fail** is set to **On**, another 2 options are available.

Press a key to change a parameter			
Test	Pass/Fai	Break	Peak
Result	Checks	Pass/Fai	Pass/Fail
Units	On	Values	Values

Pressing either the **Break Pass/Fail Limits** or **Peak Pass/Fail** Soft Keys will allow the values to be set.

Break pass/fail values

Press a key to change a parameter			
Max Load	Min	Max Ext	Min Ext
5000	100	250.00	100.00
N	N	mm	mm

7.19 DEFINING SAMPLE

Pressing the **Define Sample** Soft Key from the **Test Setup Display** will allow the sample/batch details to be set.

Press a key to change a parameter			
		Batch	Sample
Sample	Pre-test	Questions	Question
Info	Questions	Off	Off

The **Batch Questions** and **Sample Question** Soft Keys toggle between **On** and **Off** to specify which pre-test question displays will be shown.

7.0 SETTING UP A NEW TEST

Pressing the **Sample Info** Soft Key will allow the sample details to be defined.

Press a key to change a parameter			
Sample	Gauge	Width	Thickness
Type	25.00	6.00	3.00
Rect'r	mm	mm	mm

Pressing the **Sample Type** Soft Key toggles between **Rect'r / Circular / Area**. The titles **Gauge**, **Width** and **Thickness** depend upon the test mode and the sample type. The title **Gauge** becomes **Height** for Compression. The title **Width** becomes **Diameter** for Circular or **Area** for Area. The title **Thickness** is only displayed for **Rect'r**.

7.20

PRE-TEST QUESTIONS

Pressing the **Pre-test Questions** Soft Key allows the pre-test questions to be defined.

Press a key to change a parameter			
Batch 1	Batch 2	Batch 3	Sample
OPERATOR	BATCH		SAMPLE
NAME	NUMBER		NUMBE

Up to 3 batch questions and 1 sample question may be defined.

8.0 OPERATIONAL PRECAUTIONS

8.1 SAFETY

Lloyd Instruments materials testing machines are inherently safe if used properly. Operators must be made aware that:-

- 1 High physical forces are involved.
- 2 Samples under test may shatter.
- 3 Electrical power supplies are involved.
- 4 The following must **ALWAYS** be brought to the attention of any operator before they are allowed to use the machine. Hands, fingers and other parts of the body must at all times be kept well away from the moving crosshead. Operators should be particularly careful when moving the crosshead to insert test samples, to ensure that no part of the hand could be accidentally compressed as the crosshead and grips are jogged into position.
- 5 **NEVER** drive the machine from a computer when anyone else is working on or near the straining frame.
- 6 If there is any danger that liquids may be spilt during tests, operators must use a drip tray (which is available from Lloyd Instruments) to guard against the possibility of any spillage entering the machine and giving rise to electrical or other hazards.
- 7 Take extra care when operating in compression mode where specimens may burst, shatter or fly out from between the platens. Operators should **STAND CLEAR** during testing. Splinter shields are available.
- 8 All operators must receive adequate training in basic operation before being allowed to use the machine. Additional copies of this manual are available from Lloyd Instruments.

8.0 OPERATIONAL PRECAUTIONS

- 9 Operators must ensure that the **Emergency Stop Button** is never obstructed.
- 10 Operators must ensure that other personnel working in or near the area are made aware that testing is taking place and that they should not approach the machine while it is in use.
- 11 Operators must ensure that the machine is regularly serviced and calibrated by Lloyd Instruments or one of their accredited service dealers.
- 12 To maintain EMC compatibility, the machine should only be used as prescribed in this manual. Connecting cables, plugs and sockets should be inspected regularly. Cables damaged or worn in any way should not be used. Accessories and accessory connecting leads, if suspect, should be replaced only with a Lloyd Instruments approved replacement. Failure to observe this may cause your machine to infringe the EMC legal requirements.
- 13 Never attempt any form of machine maintenance without disconnecting the mains electrical supply.
- 14 Never attempt to test any samples with a type of grip or other accessory, which is not designed for that particular test. Never use grips or the machine for tests in excess of the stated load limits. A comprehensive range of alternative grips, together with an applications advisory service, is available from Lloyd Instruments and its accredited dealers.

8.0 OPERATIONAL PRECAUTIONS

8.2 EMERGENCY STOP

If for any reason the machine needs to be stopped without delay, an emergency stop mushroom is provided. Pressing this switch stops the LR *Plus* immediately. It can be released by turning a quarter of a turn clockwise. The machine will then go to the initialise / start up sequence if the ON/OFF switch is already ON.



8.3 SPLINTER SHIELDS

Transparent splinter shields are available as an option to enclose the test sample if there is any danger of samples shattering as a result of the test. These shields can be fitted with an electronic interlock so that the test cannot be started until the hinged shield is closed. While not mandatory for many applications and countries, Lloyd Instruments strongly recommend that users consider fitting this optional item.

If a shield fitted with electronic interlock is used, the following screen will appear if the door is opened during a test.

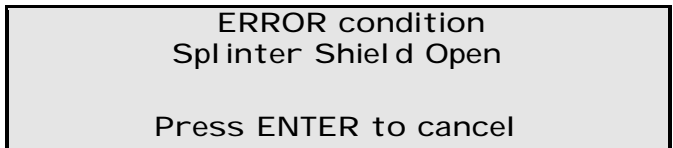

The test in progress will be aborted and the next test or a new test will have to be started.

8.0 OPERATIONAL PRECAUTIONS

8.4 LOWER ANCHOR PIN ADJUSTMENT

The Lower Anchor Pin has two locking collars, one to lock it in position in the lower (fixed) crosshead and the other to screw upwards to lock the bottom grip / fixture firmly in position.

Screw the bottom collar clockwise until it is flush with the base plate and locks the Lower Anchor Pin in position

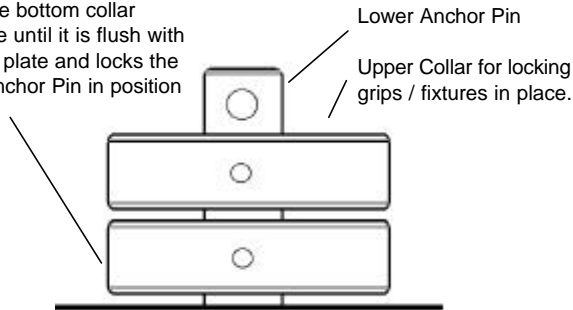

Lower Anchor pin Locking Collars

When the grips or test fixtures have been fitted to the loadcell and bottom anchor pin, carefully align the top and bottom grips or test fixtures. Turn the bottom collar clockwise until it is locked against the lower crosshead in the position required. This is particularly important when carrying out compression tests.

Extreme care must be taken when manoeuvring the crosshead, particularly when low force load cells are being used as they can easily be damaged even at moderate speeds. As an additional precaution during compression testing the lower (hardware) limit stop should be set so that the compression plates cannot come together either during or after a test.

8.0 OPERATIONAL PRECAUTIONS

8.5 LIMIT STOPS

The LR *Plus* machines are fitted with two mechanically activating limit stops. These can be used as extra protection to stop load cells, grips or fixtures coming into contact. The upper one can be used to back up the software limit. Activating a limit stop will result in the machine stopping.

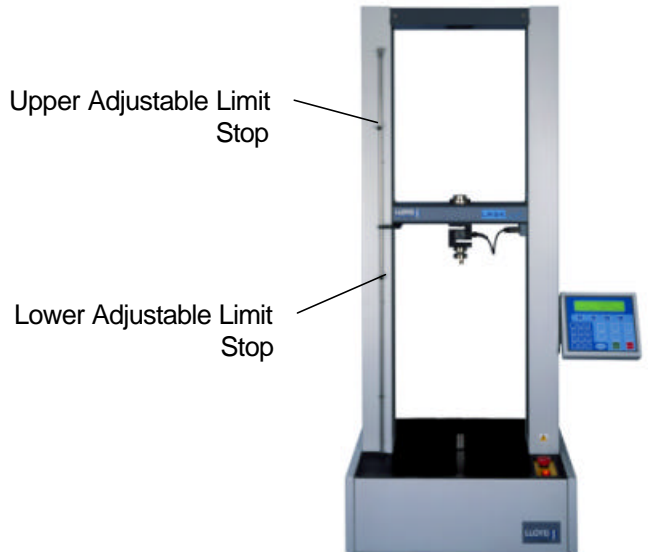

To adjust the **bottom** limit stop, drive the moving crosshead to the lowest position that it is ever going to get to safely, without damaging any fitted grips or fixtures. When this position has been reached drive the crosshead **up** by 3mm. Move the lower adjustable limit stop up to the crosshead actuator and lock in place.



Adjustable Bottom Limit Stop

8.0 OPERATIONAL PRECAUTIONS

To adjust the **top** limit stop, drive the moving crosshead to the highest position that it is ever going to get to safely, without damaging any fitted grips or fixtures. When this position has been reached drive the crosshead **down** by 3mm. Move the upper adjustable limit stop down to the cross head actuator and lock in place.



**Adjustable Top
Limit Stop**

If during a test or when manoeuvring the crosshead, a limit stop switch is activated, a display as shown below or similar will be seen.

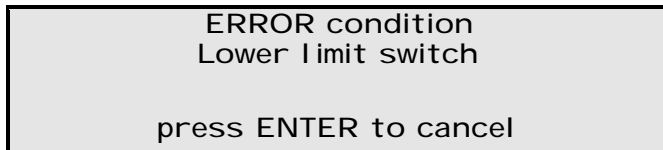

When **ENTER** has been pressed and this display has been cleared the machine will only allow the operator to drive the crosshead away from the limit stop.

8.6 ERROR CONDITIONS

On the LR *Plus* fitted with a console, if an error occurs, a message will be displayed on the console describing the error. This message must be cleared by pressing the **ENTER** key before proceeding. Some errors are displayed when the machine is first powered on and indicate faults that were detected during the power up sequence.

On LR *Plus* machines not fitted with a console, used with a computer and NEXYGEN software, similar messages will be displayed on the VDU by NEXYGEN.

8.0 OPERATIONAL PRECAUTIONS

Data Packet Error

This error indicates that an invalid data packet has been received across the RS232 interface. All data transferred via RS232 is checked for errors and resent if any error occurs, so this message should never be displayed. If it is seen it is indicative of other problems occurring either within the machine or at the PC.

Motor Drive Fault

This indicates that the motor drive system has reported an error condition.

Upper limit switch

The adjustable upper limit switch has been hit. This can be cleared by adjusting the upper limit or driving off it using the jog down keys.

Lower limit switch

The adjustable lower limit switch has been hit. This can be cleared by adjusting the lower limit, or driving off it using the jog up keys.

No Loadcell

An attempt has been made to drive the machine without a load cell connected. Ensure the load cell is properly connected and try again.

Splinter Shield Open

The splinter shield fitted to the machine is open. A test cannot be started until the splinter shield is closed.

Cell Overload

The load applied to the system is in excess of 110% of the load cell rating. Use the jog keys to remove the load.

Safety Overload

The load applied to the load cell is in excess of the safety load limit in the global settings. This limit only applies when the crosshead is moving downwards during return or under control of the jog keys.

W. D. Turner Company, Inc.
7 Whitaker Place, Thomasville, NC 27360
Phone: 336-882-4931 Fax 336-882-6175
(Sales & Service) www.WDTurner.com

8.0 OPERATIONAL PRECAUTIONS

Frame Overload

The load applied to the system is in excess of 105% of the frame rating. Use the jog keys to remove the load.

Grip Overload

The load applied to the system is in excess of the grip protection limit in the global settings. This limit only applies during a test.

Print unavailable. Power down and retry

An attempt has been made to print when the RS232 port is in use with a PC running NEXYGEN. After using the machine with NEXYGEN it is necessary to power down before it is possible to print.

Unexpected reset code XX

Unexpected software reset code XXX

Software reset code 106 (XXXXXX)

These messages indicate that an internal error has caused the system to reset unexpectedly. Please make a note of the readings and contact Lloyd Instruments Technical Support for help:-

Telephone:- + 44 (0) 1489 486 422

or

Email:- techsupport@lloyd-instruments.co.uk

System Hardware Error

An error has occurred in the internal electronics of the system.

Drive System Error

The motor control system has not been able to maintain adequate control of the motor and has shut down as a safety precaution. This will usually indicate a fault within the motor drive or extension measurement system.

Accessory Connected/Disconnected

An accessory has been connected or removed while the crosshead is being driven.

8.0 OPERATIONAL PRECAUTIONS

Load / Speed / Rating Exceeded

The machine has moved outside the load and speed rating of the machine. Ensure the test being performed is within the machine's load and speed rating

Extensometer Range Exceeded

The machine has moved outside the range of the extensometer. Ensure the test being performed is within the range of the extensometer.

9.0 CLEANING AND MAINTENANCE

9.1 CLEANING EXTERNAL FINISH AND TRIM

The finish and appearance of your machine can be maintained by regular cleaning with a damp cloth containing a small amount of mild detergent. The machine should be turned OFF and disconnected from the mains supply whilst cleaning is taking place. Strong proprietary cleaners and petroleum based or other solvents should not be used.

CAUTION: Take care to use only a damp cloth. NO moisture must ever be allowed to get into the machine. Wipe the machine dry before connecting to the mains supply and restarting.

9.2 MAINTENANCE

In normal use and conditions your machine should be serviced and calibrated annually by Lloyd Instruments Ltd. or one of their appointed agents. There are no user serviceable or adjustable parts within the machine, therefore service and calibration should only ever be undertaken by engineers trained for the task.

If the machine is being used in a particularly arduous way or under extreme conditions, your appointed service agent may recommend more frequent calibration/service.

10.0 SPECIFICATION

10.1

TECHNICAL SPECIFICATION LR5K PLUS

Maximum Force (Tension and Compression)	5kN (1100lbf)
Overall Force Range Using Interchangeable Load Cells	0.1N - 5kN (0.02 - 1100lbf)
Force Measuring System	Exceeds the requirements of BSEN ISO 7500 – 1: 1999 Class 0.5 ASTM E4, DIN 1221
Force Measuring Accuracy	Better than 0.5%
Crosshead Speed Range	0.01 - 1016mm/min at full load (0.0004 - 40in/ min at full load)
Crosshead Speed Accuracy	± 0.2% at steady state
Maximum Working Width Between Columns	404mm (16in)
Crosshead Travel (standard machine) (Extended Frame)	1000mm (40in) 1485mm (58.5in)
Internal Extension Resolution	Better than 1 micron
External Extensometer Connection. (Using Lloyd Instruments interface plug)	Analogue (0-1V), (0-10V) or strain gauge. Digital encoders (Single or dual differential)
Frame Stiffness Without Load Cell.	Greater than 25kN/mm (142,750lbf/in)
Supply Voltage	230V a.c. ±10% 50-60Hz Fuse 5A (T) or 115V a.c. ±10% 50-60Hz Fuse 10A (T)
Power Consumption	500 VA max.
Main Frame Dimensions	Height 1555mm (61in) Depth 480mm (19in) Width (without console) 638mm (25in) Width (with console) 845mm (33in)
Mass (no Load Cell or Grips fitted)	99kg (219lb)
Temperature (operating) (storage)	5 to 35°C (40°F to 95°F) -20 to 55°C (-4°F to 130°F)
Atmospheric	5 to 85% RH (Non- condensing)

Note:-

For the extended version add:-

**500mm (20 in) to the Height.
27kg (60 lb) to the Mass**

10.0 SPECIFICATION

10.2 TECHNICAL SPECIFICATION LR10K PLUS

Maximum Force (Tension and Compression)	10kN (2200lbf)
Overall Force Range Using Interchangeable Load Cells	0.1N - 10kN (0.02 - 2200lbf)
Force Measuring System	Exceeds the requirements of BSEN ISO 7500 – 1: 1999 Class 0.5 ASTM E4, DIN 1221
Force Measuring Accuracy	Better than 0.5%
Crosshead Speed Range	0.01 - 508mm/min at full load (0.0004 - 40in/ min at full load)
Crosshead Speed Accuracy	± 0.2% at steady state
Maximum Working Width Between Columns	404mm (16in)
Crosshead Travel (Standard Machine) (Extended Frame)	975mm (39.8in) 1460mm (57.5in)
Internal Extension Resolution	Better than 1 micron
External Extensometer Connection. (Using Lloyd Instruments interface plug)	Analogue (0-1V), (0-10V) or strain gauge. Digital encoders (Single or dual differential)
Frame Stiffness Without Load Cell.	Greater than 25kN/mm (142,750lbf/in)
Supply Voltage	230V a.c. ±10% 50-60Hz Fuse 5A (T) or 115V a.c. ±10% 50-60Hz Fuse 10A (T)
Power Consumption	500 VA max.
Main Frame Dimensions	Height 1555mm (61in) Depth 480mm (19in) Width (without console) 638mm (25in) Width (with console) 845mm (33in)
Mass (no Load Cell or Grips fitted)	99kg (219lb)
Temperature (operating) (storage)	5 to 35°C (40°F to 95°F) -20 to 55°C (-4°F to 130°F)
Atmospheric	5 to 85% RH (Non- condensing)

Note:-

For the extended version add:-

500mm (20 in) to the Height.

27kg (60 lb) to the Mass

10.0 SPECIFICATION

10.3 OVERALL DIMENSIONS LR5K PLUS & LR10K PLUS

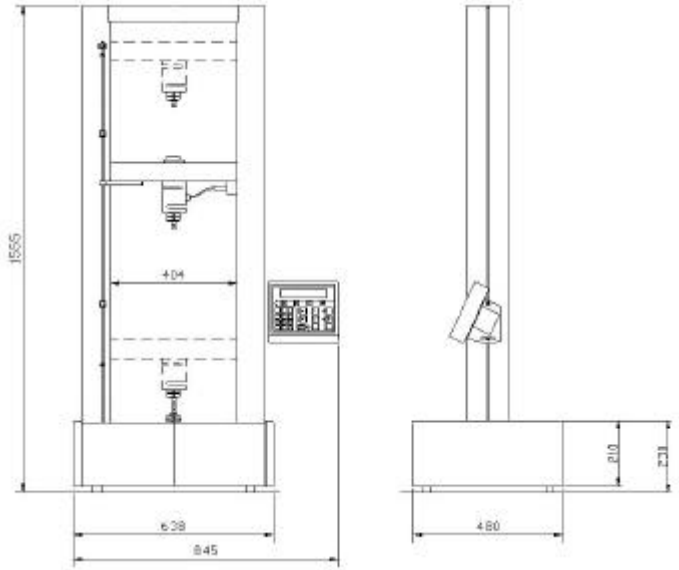

LR5K Plus and LR10K Plus External Dimensions

10.0 SPECIFICATION

10.4 RS232 LEADS

MACHINE to PC Lloyd Part No. 09/0639 (supplied).

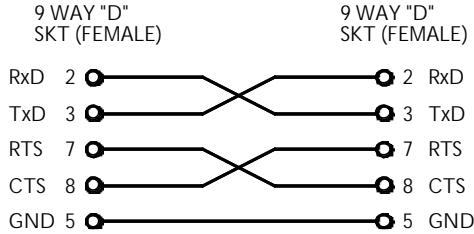

09/0639

Data rate is 57600 BAUD, 8 Bit, no parity, 1 stop Bit

MACHINE TO PRINTER Lloyd Part No. 09/0721 (optional)

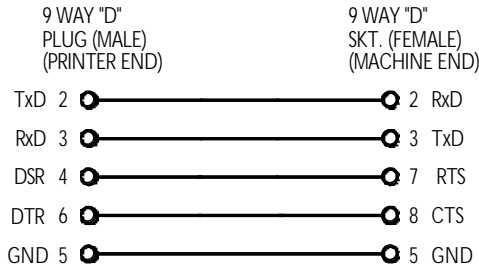

09/0721

Data rate is 9600 BAUD, 8 Bit, no parity, 1 stop Bit.

10.0 SPECIFICATION

10.5 CONSOLE LEAD

Standard, Part number 09/0710. (supplied)

900mm long lead fitted with 37 Way "D" plugs.

Connections, pin to pin
(except pins 37 which are not used)

Non- Standard Other lengths supplied to order.

Note:

To maintain EMC compliance **ONLY** leads supplied by Lloyd Instruments should be used. Check leads for signs of damage regularly. Replace leads that are damaged in any way.

Lloyd Instruments Ltd has an on-going programme of design and development which may alter product specification. Therefore Lloyd Instruments Ltd. reserve the right to change specifications at any time without notice.

No part of this manual may be reproduced or transmitted in any form without prior permission of Lloyd Instruments Ltd.